



LU-MAX

Product Catalogue | 2026

Shandong Lumax Innovative Lighting Co. Ltd.
www.sd-lumax.com

Who are Lumax

Who are Lumax

Lumax are a professional manufacturer of LED work-lights, based in Weihai, Shandong, China.

A joint venture between Ceta Form Hand Tools of Türkiye and Top-Power, China. Lumax supply private label work-lights to leading brands and distributors, worldwide. Incorporating innovation and the latest technology, Lumax aim is to be the leading manufacturers of work-lights in China.

Our Vision

Our vision is centered around delivering the most innovative LED work-lights for professional users. Whether it is a handy torch, a head-lamp, a hand-held work-light or a floor standing flood-light, all our products incorporate modern designs, high quality materials and high spec components. New and unique work-lights are being added to the range every month. Lumax work-lights are suitable for automotive, aviation, industrial, maintenance, electrical, plumbing and construction markets, to name but a few.

Product Index

LED Inspection Lights
(Full Size)

08



LED Headlamps

22



LED Color Proofing
Lights

36



LED Inspection Lights
(Mid Size)

13



LED Flood Lights (Heavy Duty)

25



UV Leak Detection
Lights

42



Slim LED Inspection
Lights (Folding)

15



LED Flood Lights (Compact)

30



Underhood Worklight

44



LED Inspection Lights
(Compact)

19



Wireless LED Lights+
Charge Docks

33



WORK LIGHT TRIPOD

46



Quality Control Capabilities

Quality

Lumax Lighting Company takes quality seriously, making sure every light we produce meets the highest standards. We have a rigorous quality control process at every step of making our lights. This means our lights not only meet the industry standards but often surpass them.

Our Labs

Our cutting-edge labs are at the heart of Lumax's commitment to ensuring the quality of our lights. These well-equipped facilities are staffed by experts who excel in their field. In these labs, we rigorously test our lights to ensure they perform flawlessly in various situations

Quality Control

We test our lights in all sorts of ways. We check how bright they are, how they handle heat, and how they perform in different environments. This ensures that our lights last a long time and work well, just like they're supposed to.

Production Capabilities

Environment

In our labs, we don't just test the lights; we also scrutinize the materials we use. We ensure that the materials are not only durable but also environmentally friendly, minimizing any negative impact on the planet. This way, you can trust that our lights are both high-quality and environmentally responsible.

Innovation

Our labs are also where we come up with new ideas and technologies for lighting. We're always working on making better and more innovative lights. This way, we stay at the forefront of the lighting industry.

High-End Product

In a nutshell, Lumax Lighting Company is dedicated to producing high-quality lights that meet the highest standards. Our labs are pivotal in making sure our lights work well, last long, and are environmentally responsible. Plus, we're continually developing new and innovative lighting solutions to lead the industry.

Our quality, will be in your brand!



100% Bespoke Manufacturing

Have you got a unique design idea? No problem, we are a competent partner to realize your project. Our design team can cooperate with you to generate 3D models and prototypes. Once approved, the necessary injection mold toolings, etc. will be developed for the desired model range. Your idea will be in serial production in truly short period. Take advantage of our offer; please feel free to talk to us for details.

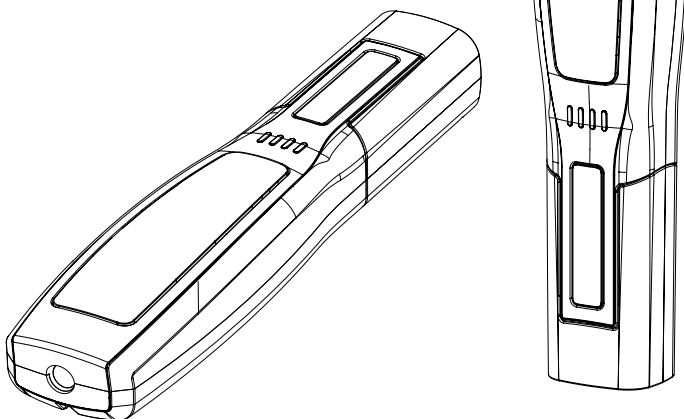

With the striking design, our polycarbon cover, keeps your logo safe for any damage



Packaging and Kits

The ultimate in quality deserves the ultimate in packaging. Therefore, we offer a limitless choice of packaging alternatives. Your brand could be on the forefront on the market with innovative packaging solutions from us.





LED Inspection Lights (Full Size)



LED Inspection Lights (Full Size)

LMA001-001

Rechargeable COB LED Inspection Light

1000
lumens
COB LED



Durable housing, hooks and lens
180 degree pivoting handle
Super strong magnets in the handle and back
4 LED battery level indicators show the charge status



Main light: 10W COB LED, 6500K, 80+CRI
Top light: 4W SMD LED, 6500K, 80+CRI



Main light: 250 / 500 / 1000 lumens
Top light: 150 lumens



Battery:
3.7V 2600 mAh Li-ion



Charging time:
3.5 h



Main light: 8 h / 4 h / 2 h
Top light: 7 h



1m Type C USB
5V-1A



IP65



IK07



339 g



268x61x42 mm

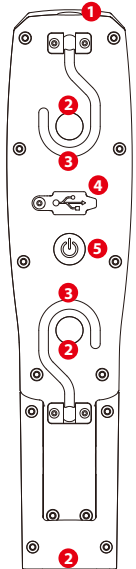

- 1 Top Light
- 2 Magnet
- 3 Rigid plastic hook
- 4 USB-C Socket
- 5 On - Off switch & Dimmer

LMA001-002S

Rechargeable SMD LED Inspection Light

700
lumens
SMD LED



Durable housing, hooks and lens
180 degree pivoting handle
Super strong magnets in the handle and back
4 LED battery level indicators show the charge status



Main light: 7W SMD LED, 6500K, 70+CRI
Top light: 4W SMD LED, 6500K, 70+CRI



Main light: 175 / 350 / 700 lumens
Top light: 100 lumens



Battery:
3.7V 2600 mAh Li-ion



Charging time:
3.5 h



Main light: 8 h / 4 h / 2 h
Top light: 10 h



1m Type C USB
5V-1A



IP54



IK07



304 g



268x61x42 mm

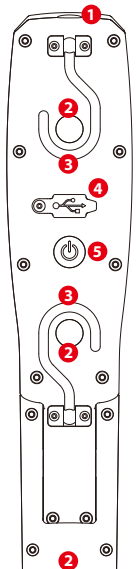

- 1 Top Light
- 2 Magnet
- 3 Rigid plastic hook
- 4 USB-C Socket
- 5 On - Off switch & Dimmer

LED Inspection Lights (Mid Size)



LMA002-001

Rechargeable COB LED Inspection Light

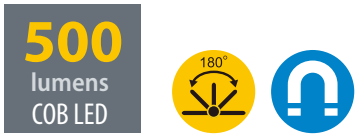

Durable housing, hooks and lens
 180 degree pivoting handle
 Super strong magnets on the bottom
 3 LED battery level indicators show the charge status



- Main light: 6W COB LED, 6500K, 80+CRI
Top light: 4W SMD LED, 6500K, 80+CRI
- Main light: 250 / 500 lumens
Top light: 100 lumens
- Battery: 3.7 V 2600 mAh Li-ion
- Charging time: 3.5 h
- Main light: 5 h / 3.5 h
Top light: 10 h
- 1m Type C USB 5V-1A
- IP54
- IK07
- 214 g
- 199x56x36 mm

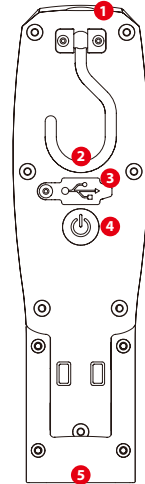

- 1** Top Light
- 2** Rigid plastic hook
- 3** USB-C Socket
- 4** On - Off switch
- 5** Magnet

LMA002-001S

Rechargeable SMD LED Inspection Light



Durable housing, hooks and lens
 180 degree pivoting handle
 Super strong magnets on the bottom
 3 LED battery level indicators show the charge status



- Main light: 6W SMD LED, 6500K, 70+CRI
Top light: 3W SMD LED, 6500K, 70+CRI
- Main light: 250 / 500 lumens
Top light: 100 lumens
- Battery: 3.7 V 2200 mAh Li-ion
- Charging time: 3.5 h
- Main light: 8 h / 4 h
Top light: 10 h
- 1m Type C USB 5V-1A
- IP54
- IK07
- 208 g
- 198x57x40 mm

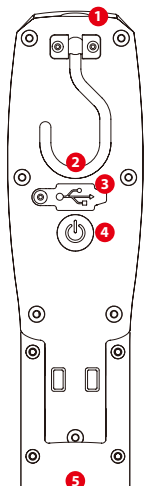

- 1** Top Light
- 2** Rigid plastic hook
- 3** USB-C Socket
- 4** On - Off switch
- 5** Magnet

LMA006-001

Rechargeable LED Inspection Light - Replaceable Lens

500
lumens
COB LED



Durable housing, hooks and lens
180 degree pivoting handle
Super strong magnets on the bottom



- Main light: 6W COB LED, 6500K, 80+CRI
Top light: 3W SMD LED, 6500K, 80+CRI
- Main light: 250 / 500 lumens
Top light: 100 lumens
- Battery:
3.7 V 2600 mAh Li-ion
- Charging time:
3.5 h
- Main light: 5 h / 3.5 h
Top light: 10 h
- 1m Type C USB
5V-1A
- IP54
- IK07
- 235 g
- 198x57x40 mm

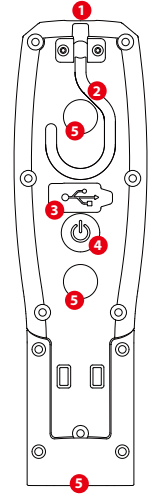

- 1** Top Light
- 2** Rigid plastic hook
- 3** USB-C Socket
- 4** On - Off switch
- 5** Magnet

LMA007-001

Rechargeable COB LED Inspection Light

400
lumens
COB LED



Long & thin design, making it easy to carry and apply.
Hook & rear magnet are suitable for various environments.
Sturdy & durable Aluminum alloy housing.



- Flood light: 6W COB LED, 6500K, 80+CRI
- Flood light: 200 / 400 lumens
- Battery:
3.7 V 1800 mAh Li-ion
- Charging time:
4 h
- Main light: 3 h / 1.5 h
- 1m Type C USB
5V-1A
- IPX4
- IK07
- 120 g
- 249x32.5x10.5 mm

LMA008-001

Rechargeable COB LED Inspection Light

1000
lumens
COB LED

Long & thin design, making it easy to carry and apply.
Sturdy & durable Aluminum alloy housing.



- Flood light: 10W COB LED, 6500K, 80+CRI
- Flood light: 250 / 500 / 1000lumens
- Battery: 3.7V 4400mAh Li-ion or 3.7V 2600mAh Li-ion
- Charging time: 4 h
- Main light: 12 h / 6 h / 3 h
- 1m Type C USB 5V-2A
- IPX0
- IK07
- 390 g
- 480x40x40 mm

LMC002-001

Mini Rechargeable COB LED Aluminium alloy penlight

300
lumens
COB LED



Dual lights desian,spotlight & floodlight. Applied with a pen clip, it can be clipped to the pocket or something else.



- Main light: 3W COB LED, 6000-7000K, 80+CRI
Top light: 2W SMD LED, 6000-7000K, 80+CRI
- Main light: 300 lumens
Top light: 200 lumens
- Battery: 3.7 V 700 mAh Li-ion
- Charging time: 2 h
- Main light: 2 h
Top light: 3 h
- 1m Type C USB 5V-1A
- IP20
- IK07
- 58 g
- 170x21x20 mm



- 1** On - Off switch
- 2** Magnet
- 3** Rigid plastic hook
- 4** Top Light

LED Inspection Lights (Min Size)

LMC001-001

Mini Rechargeable COB LED Inspection Light

150
lumens
COB LED



Durable housing and lens
Strong magnet on the clip
Led charging indicator:
Red while charging, green when full



Main light: 3W COB LED, 6500K, 80+CRI
Top light: 1W SMD LED, 6500K, 80+CRI



Main light: 150 lumens
Top light: 80 lumens



Battery:
3.7 V 800 mAh Li-ion



Charging time:
2 h



Main light: 3 h
Top light: 5 h



1m Type C USB
5V-1A



IP20



IK07



62 g



167x25x27 mm



- 1 Top Light
- 2 Magnet
- 3 Rigid plastic hook
- 4 On - Off switch
- 5 USB-C Socket

LMC001-001S

Mini Rechargeable SMD LED Inspection Light

150
lumens
COB LED



Durable housing and lens
Strong magnet on the clip
Led charging indicator:
Red while charging, green when full



Main light: 3W SMD LED, 6500K, 80+CRI
Top light: 1W SMD LED, 6500K, 80+CRI



Main light: 150 lumens
Top light: 80 lumens



Battery:
3.7 V 800 mAh Li-ion



Charging time:
2 h



Main light: 3 h
Top light: 5 h



1m Type C USB
5V-1A



IP20



IK07



61 g



167x25x27 mm



- 1 Top Light
- 2 Magnet
- 3 Rigid plastic hook
- 4 On - Off switch
- 5 USB-C Socket



Slim LED Inspection Lights (Folding)



Slim LED Inspection Lights (Folding)

LMF001-001

Folding Rechargeable SLIM LED Inspection Light

1000
lumens
COB LED



Durable plastic housing, aluminum LED frame
 Strong magnet and hook at the bottom
 180 degree rotating head in vertical position
 4 LED battery level indicators show the charge status

Flood light: 10W COB LED, 6500K, 80+CRI
 Spot light: Super Bright LED, 6500K, 80+CRI

Flood light: 1000 / 500 / 250 lumens
 Spot light: 150 lumens

Battery:
 3.7V 2600 mAh Li-ion

Charging time:
 3.5 h

Flood light: 2 / 4 / 8 h
 Spot light: 7 h

1m Type C USB
 5V-1A

IP65

IK07

295 g

Fold: 195x46x60 mm
 Extend: 348x46x60 mm

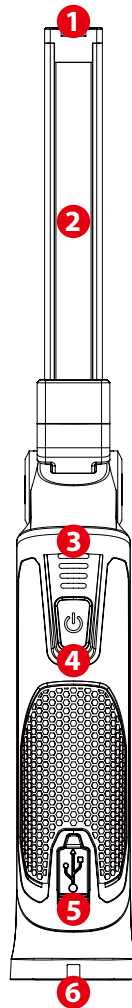

- 1 Top light
- 2 Main light
- 3 Battery indicator
- 4 On-Off switch
- 5 USB-C socket
- 6 Hook and magnet



Slim LED Inspection Lights (Folding)



LMF002-001

Swivel Head Rechargeable LED Torch

1000
lumens
COB LED



Durable plastic housing, aluminum torch head
Strong magnet and hook at the bottom
135 degree pivoting torch head
4 LED battery level indicators show the charge status
Variable lighting focal length



- Torch light: 10W Super Bright LED, 6500K, 70+CRI
- Torch light: 1000 / 500 / 250 lumens
- Battery: 3.7V 2600 mAh Li-ion
- Charging time: 3.5 h
- Torch light: 2 / 4 / 7 h
- 1m Type C USB 5V-1A
- IP65
- IK07
- 320 g
- 251x46x60 mm

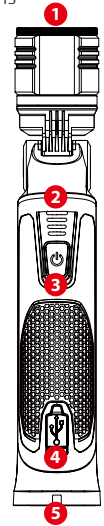

- 1** Torch Light
- 2** Battery level indicator
- 3** On - Off switch
- 4** USB-C Socket
- 5** Hook and magnet

LMF003-001

Folding Rechargeable SLIM LED Inspection Light - Mini

300
lumens
COB LED



Durable plastic housing, aluminum LED frame
Strong magnet on the bottom and back
180 degree rotating head in vertical position
During charging, the red led flashes, green led indicates fully charged.



- Flood light: Super Bright COB LED, 6500K, 80+CRI
Spot light: Super Bright LED, 6500K, 80+CRI
Back light: COB LED, 6500 K, 80+CRI
- Flood light: 300Lm
Flood Econ: 150Lm
Spot light: 80 lumens
Back light: 200 lumens
- Battery: 3.7V 800 mAh Li-ion
- Charging time: 2 h
- Flood light: 1.5h Econ: 3h
Spot light: 3 h
Back light: 2 h
- 1m Type C USB 5V-1A
- IP54
- IK07
- 80 g
- Fold: 158x20x32 mm
Extend: 301x20x25 mm



- 1** Top Light
- 2** Main light
- 3** Magnet
- 4** Battery Indicator
- 5** On - Off switch
- 6** USB-C socket
- 7** Magnet
- 8** Magnet

Slim LED Inspection Lights (Folding)

LMF005-001

Aluminium Folding Rechargeable SLIM inspection light

600
lumens
COB LED



The light strip can rotate 180 degrees and be folded up for easy storage and portability. The bottom is equipped with a pull-out clamp function, which can be fixed to different thicknesses of plates, and the maximum stretching size can reach 45MM. The magnet at the bottom can be attached to the engine hood, tool rack, etc. and the hook can be hung.



- Flood light: 4W COB LED, 6500K, 80+CRI
Spot light: 2W SMD LED, 6500K, 80+CRI
Top light: 1W SMD LED, 6500K, 80+CRI
- Flood light: 600 lumens / Red light: 10 lumens
Spot light: 200 lumens
Top light: 60 lumens
- Battery:
3.7 V 2600mAh Li-ion
- Charging time:
3.5 h
- Flood light: 3 h / Red light: 20 h
Spot light: 10 h
Top light: 40 h
- 1m Type C USB
5V-1A
- IPX0
- IK07
- 180 g
- 158x31x45mm

LMF006-001

Aluminium Folding Rechargeable SLIM inspection light

400
lumens
COB LED



The light strip can rotate 180 degrees and be folded up for easy storage and portability. The bottom is equipped with a pull-out clamp function, which can be fixed to different thicknesses of plates, and the maximum stretching size can reach 45MM. The magnet at the bottom can be attached to the engine hood, tool rack, etc. and the hook can be hung.



- Flood light: 3W COB LED, 6500K, 80+CRI
Spot light: 2W SMD LED, 6500K, 80+CRI
Top light: 1W SMD LED, 6500K, 80+CRI
- Flood light: 400 lumens / Red light: 12 lumens
Spot light: 200 lumens
Top light: 60 lumens
- Battery:
3.7 V 1200mAh Li-ion
- Charging time:
2 h
- Flood light: 2 h / Red light: 12 h
Spot light: 4.5 h
Top light: 20 h
- 1m Type C USB
5V-1A
- IPX0
- IK07
- 119 g
- 130x27x41mm



LED Inspection Lights (Compact)



LED Inspection Lights (Compact)

LMB001-001

Compact Rechargeable COB LED Inspection Light

400
lumens
COB LED



Durable housing, hook & lens
360 degree pivoting frame
Strong magnet on clip and
bottom Led charging indicator:
Red while charging, green
when full



WIDE AREA LENS



Main light: 3W COB LED, 6500K, 80+CRI



Main light: 400 / 120 lumens



Battery:
3.7 V 1500 mAh Li-ion



Charging time:
3 h



Main light: 3 / 8 h



1m Type C USB
5V-1A



IP54



IK07



166 g



127x69x33 mm

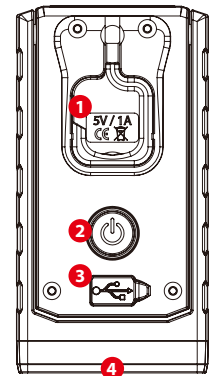

- 1 Rigid plastic hook and belt clip
- 2 On - Off switch
- 3 USB-C Socket
- 4 Magnet

LMB001-001S

Compact Rechargeable SMD LED Inspection Light

300
lumens
SMD LED



Durable housing, hook & lens
360 degree pivoting frame
Strong magnet on clip and
bottom Led charging indicator:
Red while charging, green
when full



WIDE AREA LENS



Main light: 3W SMD LED, 6500K, 80+CRI



Main light: 300 / 100 lumens



Battery:
3.7 V 1500 mAh Li-ion



Charging time:
3 h



Main light: 3 / 8.5 h



1m Type C USB
5V-1A



IP54



IK07



160 g



127x69x33 mm

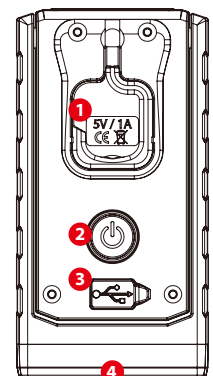

- 1 Rigid plastic hook and belt clip
- 2 On - Off switch
- 3 USB-C Socket
- 4 Magnet

LED Inspection Lights (Compact)



LMB003-001

Compact Rechargeable COB LED Inspection Light

1200
lumens
COB LED



Strong magnet on clip and bottom

Led charging indicator:
Red while charging, green when full
AL case



Main light: 10W COB LED, 6000-7000K, 80+CRI
Top light: 2W SMD LED, 6000-7000K, 80+CRI



Main light: 80 / 600 / 1200 lumens
Top light: 100 lumens



Battery:
3.7 V 2000 mAh Li-ion



Charging time:
3 h



Main light: 12 / 5.5 / 1.5 h
Top light: 10 h



1m Type C USB
5V-1A



IP65



IK07



160 g



120x44x29 mm

LMB004-001

Mini Aluminium Pocket light

400
lumens
COB LED



Strong magnet on clip and bottom

Led charging indicator:
Red while charging, green when full
AL case



Main light: 4W COB LED, 6500K, 80+CRI
Top light: 2W SMD LED, 6500K, 80+CRI



Main light: 200 / 400 / 620-630 lumens
Top light: 100 lumens



Battery:
3.7 V 800 mAh Li-ion



Charging time:
2 h



Main light: 3 / 2 / 5 h
Top light: 5 h



1m Type C USB
5V-1A



IP20



IK07



120 g



115x28x15 mm



LED Headlamps

LMD001-001

Rechargeable LED Headlamp with Motion Sensor

400
lumens
COB LED





Durable housing and lens
 Strong belt with non-slip grip
 Smart motion sensor
 Led charging indicator: Flashing green while charging,
 solid green when full



 Main light: 4W COB LED, 6500K, 80+CRI

 Main light: 200 / 400 lumens

 Battery:
3.7 V 1500 mAh Li-ion

 Charging time:
2.5 h

 Main light: 6 / 2 h

 1m Type C USB
5V-1A

 IP65

 IK07

 110 g

 78.5x47.5x42 mm

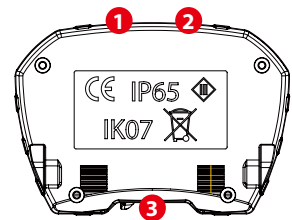

- 1** IR sensor switch
- 2** On - Off switch
- 3** USB-C Socket

LMD002-001

LED Headlamp - 3xAAA

150
lumens
COB LED





Durable housing and lens
 Strong belt with non-slip grip



 Main light: 3W COB LED, 6500K, 80+CRI

 Main light: 40 / 150 lumens

 Battery:
3xAAA (not included)

 Warning light burst - SOS

 Main light: 8 / 2 h

 IP20

 65 g

 78x50x43 mm

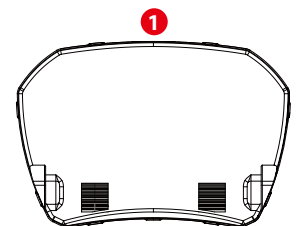

- 1** On-Off switch

LMD003-001

Rechargeable LED Headlamp with Motion Sensor

500
lumens
COB+SMD LED



SPOTLIGHT / FLOODLIGHT

Durable housing and lens

Strong belt with non-slip grip, 3 strong magnets on back Smart motion sensor

Led charging indicator: Flashing green while charging, solid green when full



Flood light: 3W COB LED, 6500K, 80+CRI
Spot light: 4W SMD LED, 6500K, 80+CRI



Flood light: 250 lumens
Spot high: 300 lumens
Spot low: 120 lumens
Spot+Flood: 500 lumens



Battery:
3.7 V 1500 mAh Li-ion



Charging time:
2.5 h



Flood light: 3h
Spot High: 3h
Spot Low: 8h
Flood +Spot: 1.5h



1m Type C USB
5V-1A



IP65



IK07



128 g



78.5x47.5x42 mm

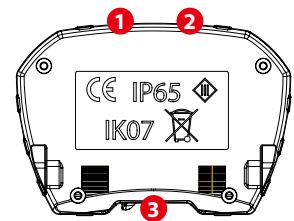

- 1** IR sensor switch
- 2** On - Off switch
- 3** USB-C Socket



Heavy Duty LED Floodlights



Heavy Duty LED Floodlights

LME009-001

Rechargeable Heavy Duty LED Floodlight

6000
lumens
COB LED



Hybrid system, can be used both on battery and AC adapter power supply
Durable aluminum housing
LED charge level indicators on back
Pivoting stand with tripod mount housings Sold separately



Main light: 60W COB LED, 80+CRI



Main light: 600/1500/3000/4500/6000 lumens



Battery:
14.8 V 4400mAh (60Wh)



Charging time:
2 h



Main light: 20 /8 /6 /4 /2h



DC 2.0
16.8~18V-2A



IP65



IK07



2050 g



258x255x122 mm



- 1 On/Off Switch
- 2 Dc 2.0 input
- 3 Usb output 5V/3A
- 4 Power Indication
- 5 Lm Indication

LME009-002

Heavy Duty LED Floodlight - for use with battery packs

6000
lumens
COB LED



Can be fitted by market leading power tool battery packs, ships with adaptors for each brand
Durable aluminum housing
LED charge level indicators on back
Pivoting stand with tripod mount housings Sold separately



Main light: 60W COB LED, 80+CRI



Main light: 600/1500/3000/4500/6000 lumens
AC Adaptor mode: 600/1500/2000/2500/3000



Battery:
18V or 20V Tool Batteries Pack



Main light:
Depends on the branded battery



DC 2.0
16.8~18V-2A



IP65



IK07



1750 g



258x255x122 mm



- 1 On/Off Switch
- 2 Dc 2.0 input
- 3 Usb output 5V/3A
- 4 Power Indication
- 5 Lm Indication

Heavy Duty LED Floodlights



LME010-001

Rechargeable Heavy Duty LED Floodlight - with diffusor, non-blinding

6000
lumens
SMD LED



Hybrid system, can be used both on battery and AC adapter power supply
Diffusor secures non-blinding light source
Durable Nylon Housing
LED charge level indicators on back
Pivoting stand with tripod mount housings Sold separately



Main light: 60W SMD LED, 80+CRI



Main light: 600/1500/3000/4500/6000 lumens



Battery:
14.8 V 4400mAh (60Wh)



Charging time:
2 h



Main light: 20 /8 /6 /4 /2h



DC 2.0
16.8~18V-2A



IP65



IK07



1700 g



258x255x122 mm



- 1 On/Off Switch
- 2 Dc 2.0 input
- 3 Usb output 5V/3A
- 4 Power Indication
- 5 Lm Indication

LME010-002

Heavy Duty LED Floodlight with Diffusor - for use with battery packs

6000
lumens
SMD LED



Can be fitted by market leading power tool battery packs, ships with adaptors for each brand
Diffusor secures non-blinding light source
Durable Nylon Housing
LED charge level indicators on back
Pivoting stand with tripod mount housings Sold separately



Main light: 60W SMD LED, 80+CRI



Main light: 600/1500/3000/4500/6000 lumens
AC Adaptor mode: 600/1500/2000/2500/3000



Battery:
18V or 20V Tool Batteries Pack



Main light:
Depends on the branded battery



DC 2.0
16.8~18V-2A



IP65



IK07



1350 g



258x255x122 mm



- 1 On/Off Switch
- 2 Dc 2.0 input
- 3 Usb output 5V/3A
- 4 Power Indication
- 5 Lm Indication

LED Flood Lights (Compact)

LME001-001

Compact Rechargeable LED Floodlight

1000
lumens
COB LED



Durable housing and lens. 180 degree flexible handle. Super strong magnet on the handle. 4 LED battery level indicators during charging and discharging.



- Flood light: 10W COB LED, 5500-6500K
Spot light: Super Bright LED, 5500-6500K, 70+CRI
- Flood light: 250 / 500 / 1000 lumens
Spot light: 250 lumens
- Battery: 3.7V 2600 mAh Li-ion
- Charging time: 3.5 h
- Flood light: 10 / 5 / 2 h
Spot light: 6 h
- 1m Type C USB 5V-1A
- IP65
- IK07
- 267 g
- 91x84x52 mm

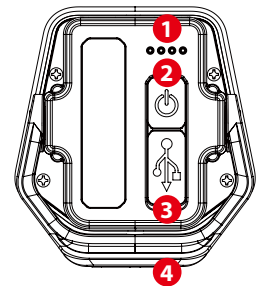

- 1** Battery level indicator
- 2** On - Off switch
- 3** USB-C Socket
- 4** Magnet on bottom

LME002-001

Compact Rechargeable LED Floodlight

2000
lumens
COB LED



Durable housing and lens. 180 degree flexible handle. Super strong magnet on the handle. 4 LED battery level indicators during charging and discharging.



- Flood light: 20W COB LED, 5500-6500K
Spot light: Super Bright LED, 5500-6500K, 70+CRI
- Flood light: 500 / 1000 / 2000 lumens
Spot light: 450 lumens
- Battery: 3.7V 5000 mAh Li-ion
- Charging time: 4 h
- Flood light: 7 / 4 / 2 h
Spot light: 5 h
- 1m Type C USB 5V-2A
- IP65
- IK07
- 400 g
- 113x104x62 mm

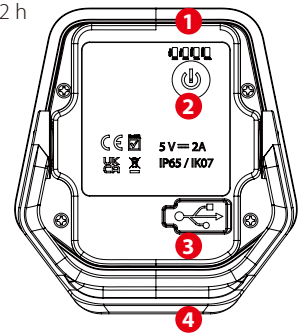

- 1** Battery level indicator
- 2** On - Off switch
- 3** USB-C Socket
- 4** Magnet on bottom

Heavy Duty LED Floodlights



LME006-001NZ

Rechargeable LED Floodlight

3500
lumens
COB LED



Durable Nylon Housing
LED indicators on the back
Pivoting stand with tripod mount
Sold separately



Flood light: 30W COB LED, 6500K, 80+CRI



Flood light: 850/1750 /2600 /3500 lumens



Battery:
14.8 V 4S1P 2200 mAh Li-ion



Charging time:
TYPE-C 5V 2A 4h



Flood light:
12h /8h /4h /2h



TYPE-C



IP65



IK07



900 g



160x120x 208 mm



- 1 On/Off Switch
- 2 Usb output 5V/2A
- 3 Power Indication
- 4 Lm Indication

LME006-001

Rechargeable LED Floodlight

3500
lumens
SMD LED



Can be fitted by market leading
power tool battery packs, ships with adaptors
for each brand
Durable Nylon housing with Aluminium
casting Heat Sink
LED indicators on the back
Pivoting stand with tripod mount Sold
separately



Flood light: 30W COB LED, 6500K, 80+CRI



Flood light: 850 /1750 /2600 /3500 lumens



Battery:
18-20V Battery Pack



Flood light: 18V 2AH



IPX0



IK07



700 g



160x120x 231 mm



- 1 On/Off Switch
- 2 Usb output 18V/2AH
- 3 Power Indication
- 4 Lm Indication



Work Light Tripod

Heavy Duty LED Floodlights



LMR002-001

Rechargeable Heavy Duty LED Floodlight - with diffuser, non-blinding

7000
lumens
SMD LED



Hybrid system, can be used both on battery and AC adapter power supply
Diffuser secures non-blinding light source
Durable Nylon Housing
LED charge level indicators on back
Pivoting stand with tripod mount housings Sold separately



- Main light: 60W SMD LED, 80+CRI
- Main light: 700/1750/3500/5250/7000 lumens
- Battery: 14.8 V 4400mAh (60Wh)
- Charging time: 2 h
- Main light: 20 /8 /6 /4 /2h
- DC 2.0 16.8~18V-2A
- IP65
- IK07
- 1700 g
- 207x169x305 mm

LMR002-002

Heavy Duty LED Floodlight with Diffuser - for use with battery packs

7000
lumens
COB LED



Can be fitted by market leading power tool battery packs, ships with adaptors for each brand
Diffuser secures non-blinding light source
Durable Nylon Housing
LED charge level indicators on back
Pivoting stand with tripod mount housings Sold separately



- Main light: 60W SMD LED, 80+CRI
- Main light: 700/1750/3500/5250/7000 lumens
AC Adaptor mode: 700/1750/3500/5250/7000
- Battery: 18V or 20V Tool Batteries Pack
- Main light: Depends on the branded battery
- DC 2.0 16.8~18V-2A
- IP65
- IK07
- 1350 g
- 207x169x305 mm

Wireless LED Lights + Charge Docks



Lumax Wireless Charging System

Ideal for workshops and garages where LED work lights are frequently used. Wall mounted dock wireless charging system eliminates the need for multiple number of chargers and charge points. Increased efficiency in workshops.



Charging docks can be connected to each other for max 3 lights charging

LMA001-001W

Rechargeable COB LED Inspection Light -
Wireless Charge

1000
lumens
COB LED



Durable housing, hooks and lens
180 degree pivoting handle
Super strong magnets in the handle and back
4 LED battery level indicators show the charge status



Main light: 10W COB LED, 6500K, 80+CRI
Top light: 4W SMD LED, 6500K, 80+CRI



Main light: 250 / 500 / 1000 lumens
Top light: 150 lumens



Battery:
3.7 V 2600 mAh Li-ion



Charging time:
3.5 h



Main light: 8 h / 4 h / 2 h
Top light: 7 h



Wireless charging time: 3.5



1m Type C USB
5V-1A



IP65



IK07



345 g



268x61x42 mm

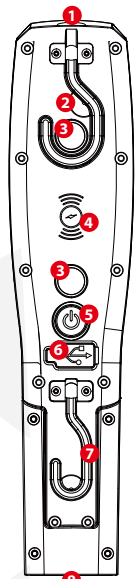

- 1 Top Light
- 2 Hook
- 3 Magnet
- 4 Wireless Area
- 5 On - Off switch
- 6 USB-C Socket
- 7 Hook
- 8 Magnet

Wireless LED Lights + Charge Docks

LMF001-001W

Folding SLIM LED Inspection Light - Wireless Charge

1000
lumens
COB LED



Durable plastic housing, aluminum LED frame
Strong magnet and hook at the bottom
180 degree rotating head in vertical position
4 LED battery level indicators show the charge status



- Flood light: 10W COB LED, 6500K, 80+CRI
Spot light: Super Bright LED, 6500K, 80+CRI
- Flood light: 250 / 500 / 1000 lumens
Spot light: 150 lumens
- Battery: 3.7 V 2600 mAh Li-ion
- Charging time: 3.5 h
- Flood light: 8 / 4 / 2 h
Spot light: 7 h
- Wireless charging time: 3.5
- 1m Type C USB 5V-1A
- IP65
- IK07
- 320 g
- Fold: 195x46x60 mm
Extend: 348x46x60 mm

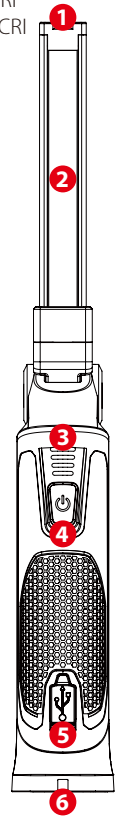

- 1 Top light
- 2 Main light
- 3 Battery indicator
- 4 On-Off switch
- 5 USB-C socket
- 6 Hook and magnet

LMF002-001W

Swivel Head LED Torch - Wireless Charge

1000
lumens
COB LED



Durable plastic housing, aluminum torch head
Strong magnet and hook at the bottom
180 degree pivoting torch head
4 LED battery level indicators show the charge status
Variable lighting focal length



- Torch light: 10W Super Bright LED, 6500K, 70+CRI
- Torch light: 250 / 500 / 1000 lumens
- Battery: 3.7 V 2600 mAh Li-ion
- Charging time: 3.5 h
- Torch light: 7 / 4 / 2 h
- Wireless charging time: 3.5
- 1m Type C USB 5V-1A
- IP65
- IK07
- 330 g
- 251x46x44 mm

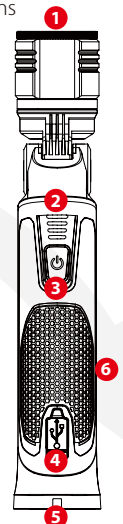

- 1 Torch Light
- 2 Battery level indicator
- 3 On - Off switch
- 4 USB-C Socket
- 5 Hook and magnet
- 6 Wireless charge area

LME002-001W

Compact LED Floodlight - Wireless Charge

2000
lumens
COB LED



Durable housing and lens.
180 degree flexible handle.
Super strong magnet on the handle.
4 LED battery level indicators during charging and discharging.



Flood light: 20W COB LED, 5500-6500K
Spot light: Super Bright LED, 5500-6500K, 70+CRI



Flood light: 500 / 1000 / 2000 lumens
Spot light: 450 lumens



Battery:
3.7 V 5000 mAh Li-ion



Charging time:
4 h



Flood light: 7 / 4 / 2 h
Spot light: 5 h



Wireless charging time: 6.5 h



1m Type C USB
5V-2A



IP65



IK07



400 g



113x104x62 mm

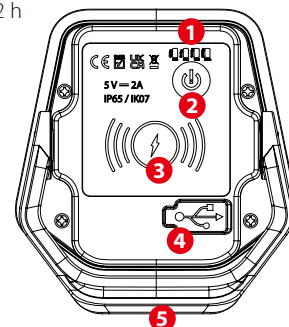

- 1 Battery level indicator
- 2 On - Off switch
- 3 Wireless area
- 4 USB-C Socket
- 5 Magnet on bottom

LMZ001-001 LMZ001-002L

LMZ001-003 LMZ001-002R

Wireless Charging Dock

Charging distance: 0-6mm

Bottom Magnetic (Adsorption of 1mm iron plate): $\geq 34N$

Working Temperature: -10~+40°C



1m Type C USB
5V-2A



IK07



153 g



116x112x17 mm



It is possible to charge the mobile phone, and it can charge the working light and the mobile phone at the same time.

LED Color Proofing Lights



CMS01

4PCS Colour Match Light

COB LED , 96+CRI

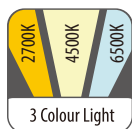

LMA006-003
LMD001-002
LME003-002

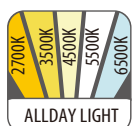

LME004-002

Designed for colour matching, detailing, and general paintwork, these work lights provide clear and consistent illumination to ensure precise inspection of painted surfaces. Suitable for use in any environment where accurate colour assessment is essential.



LED Color Proofing Lights

LMD001-002

Colour Match Rechargeable LED Headlamp with Motion Sensor

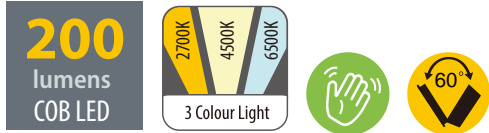

Provides different levels of CRI, ideal for detailing jobs
 Durable housing and lens
 Strong belt with non-skip grip
 Smart motion sensor
 Led charging indicator: Flashing green while charging, solid green when full



- Main light: 6W COB LED, 2700K /4500K /6500K, 96+CRI
- Main light: 200 lumens
- Battery: 3.7 V 1500 mAh Li-ion
- Charging time: 2.5 h
- Main light: 3.5 h
- 1m Type C USB 5V-1A
- IP65
- IK07
- 110 g
- 78.5x47.5x42 mm

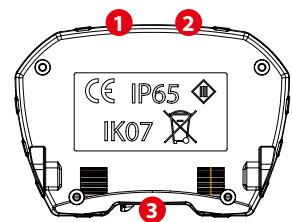

- 1** IR sensor switch
- 2** On - Off switch
- 3** USB-C Socket

LMA006-003

Colour Match Rechargeable LED Inspection Light - Replaceable Lens

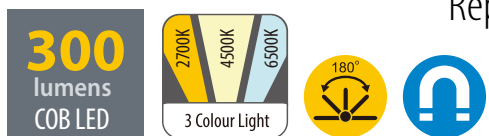

Durable housing, hooks and lens
 180 degree pivoting handle
 Super strong magnets on the bottom
 3 LED battery level indicators show the charge status



- Main light: 10W COB LED, 2700K/4500K/6500K, 96+CRI
Top light: 3W SMD LED, 6500K, 96+CRI
- Main light: 250 / 270 /300 lumens
Top light: 100 lumens
- Battery: 3.7 V 2600 mAh Li-ion
- Charging time: 3.5 h
- Main light: 3.5 h
Top light: 10 h
- 1m Type C USB 5V-1A
- IP54
- IK07
- 235 g
- 198x57x40 mm

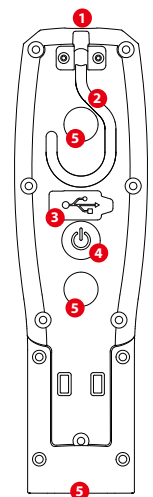

- 1** Top Light
- 2** Rigid plastic hook
- 3** USB-C Socket
- 4** On - Off switch
- 5** Magnet

LME003-002

Colour Match Compact Rechargeable LED Floodlight

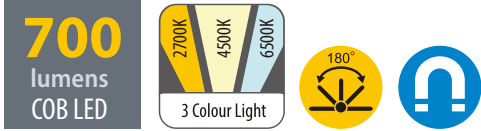

Provides different levels of CRI, ideal for detailing jobs
 Durable housing and lens.
 180 degree flexible handle.
 Super strong magnet on the handle.
 4 LED battery level indicators during charging and discharging.



- Flood light: 10W COB LED, 2700K /4500K /6500K, 96+CRI
- Flood light: 700 lumens
- Battery: 3.7 V 2600 mAh Li-ion
- Charging time: 3.5 h
- Flood light: 2 h
- 1m Type C USB 5V-1A
- IP65
- IK07
- 267 g
- 91x84x52 mm

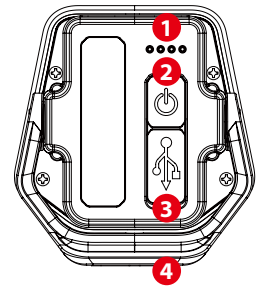

- 1** Battery level indicator
- 2** On - Off switch
- 3** USB-C Socket
- 4** Magnet on bottom

LME004-002

Colour Match Compact Rechargeable LED Floodlight

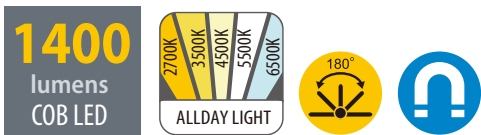

Provides different levels of CRI, ideal for detailing jobs
 Durable housing and lens.
 180 degree flexible handle.
 Super strong magnet on the handle.
 4 LED battery level indicators during charging and discharging.



- Flood light: 20W COB LED, 2700K/3500K/4500K/5500K/6500K, 96+CRI
- Flood light: 1400 lumens
- Battery: 3.7 V 5000 mAh Li-ion
- Charging time: 3.5 h
- Flood light: 2 h
- 1m Type C USB 5V-2A
- IP65
- IK07
- 400 g
- 113x104x62 mm

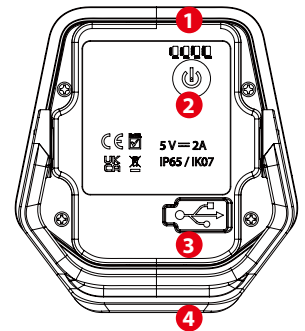

- 1** Battery level indicator
- 2** On - Off switch
- 3** USB-C Socket
- 4** Magnet on bottom

LME009-003

Colour Match Heavy Duty LED Floodlight

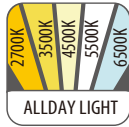

Hybrid system, can be used both on battery and AC adapter power supply

Durable aluminum housing

LED charge level indicators on back

Pivoting stand with tripod mount housings Sold separately



Main light: 60W COB LED, 90+CRI



Main light: 4000/4300/4600/4800/5000lumens



Battery: 14.8 V Battery Pack



Main light: Depends on the branded battery



DC 2.0 16.8V-2A



IP65



IK07



2300 g



258x255x122 mm



- 1 On/Off Switch
- 2 Dc 3.5 input
- 3 Usb output 5V/3A
- 4 Power Indication
- 5 Lm Indication

LME010-003

Colour Match Heavy Duty LED Floodlight



Hybrid system, can be used both on battery and AC adapter power supply

Durable aluminum housing

LED charge level indicators on back

Pivoting stand with tripod mount housings Sold separately



Main light: 60W COB LED, 90+CRI



Main light: 5000 lumens



Battery: 14.8 V Battery Pack



Main light: Depends on the branded battery



DC 2.0 16.8V-2A



IP65



IK07



2300 g



258x255x122 mm



- 1 On/Off Switch
- 2 Dc 3.5 input
- 3 Usb output 5V/3A
- 4 Power Indication
- 5 Lm Indication

LED Color Proofing Lights



LME006-003NZ

Rechargeable LED Floodlight

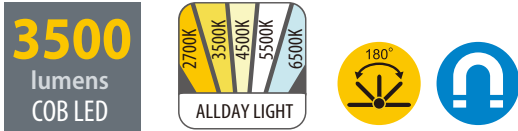

Durable Nylon Housing
LED indicators on the back
Pivoting stand with tripod mount
Sold separately



- Flood light: 30W COB LED, 6500K ,80+CRI
- Flood light: 850/1750 /2600 /3500 lumens
- Battery: 14.8V 4S1P 2200 mAh Li-ion
- Charging time: TYPE-C 5V 2A 4h
- Flood light: 12h /8h /4h /2h
- TYPE-C DC 2.0 (OPTION)
- IP65
- IK07
- 900 g
- 160x120x 208 mm



- 1** On/Off Switch
- 2** Dc 2.0 input
- 3** Usb output 5V/2A
- 4** Power Indication
- 5** Lm Indication
- 6** Kelvin Button

LME006-003

Rechargeable LED Floodlight



Hybrid system, can be used both on battery and AC adapter power supply;
Can be fitted by market leading power tool battery packs, ships with adaptors for each brand
Durable Nylon housing with Aluminium casting Heat Sink
LED indicators on the back
Pivoting stand with tripod mount Sold separately



- Flood light: 30W COB LED, 6500K ,80+CRI
- Flood light: 850/1750 /2600 /3500 lumens
- Battery: 18-20V Battery Pack
- Flood light: 18V 2AH
- DC 2.0 16.8V -2A
- IPX0
- IK07
- 700 g
- 160x120x 231 mm



- 1** On/Off Switch
- 2** Dc 2.0 input
- 3** Usb output 18V/2AH
- 4** Power Indication
- 5** Lm Indication
- 6** Kelvin Button



Leak Detection UV Lights



LMA002-002

Rechargeable UV Leak Detection Light

395
Nanometer
COB LED



For detection of leakages in cooling systems, used with UV detection liquid
Durable housing, hook and lens
180 degree pivoting handle
Super strong magnets on the bottom
3 LED battery level indicators show the charge status

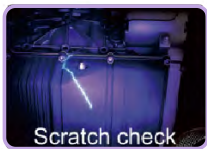

- Main light: 3W UV COB LED
Top light: 4W SMD LED, 6500K, 80+CRI
- Main light: 395 nm
Top light: 100 lumens
- Battery:
3.7 V 2600 mAh Li-ion
- Charging time:
3.5 h
- Main light: 4.5 h
Top light: 10 h
- 1m Type C USB
5V-1A
- IP54
- IK07
- 212 g
- 199x56x36 mm

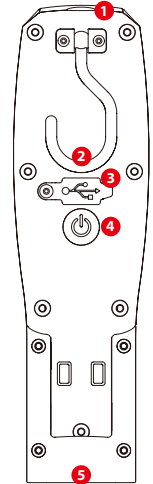

- 1** Top Light
- 2** Rigid plastic hook
- 3** USB-C Socket
- 4** On - Off switch
- 5** Magnet

LMA006-002

Rechargeable UV Leak Detection Light - Replaceable Lens

395
Nanometer
COB LED



For detection of leakages in cooling systems, used with UV detection liquid
Durable housing, hook and lens
180 degree pivoting handle
Super strong magnets on the bottom
3 LED battery level indicators show the charge status



- Main light: 3W UV COB LED
Top light: 3W SMD LED, 6500K, 80+CRI
- Main light: 395 nm
Top light: 100 lumens
- Battery:
3.7 V 2600 mAh Li-ion
- Charging time:
3.5 h
- Main light: 4.5 h
Top light: 10 h
- 1m Type C USB
5V-1A
- IP54
- IK07
- 235 g
- 198x57x40 mm

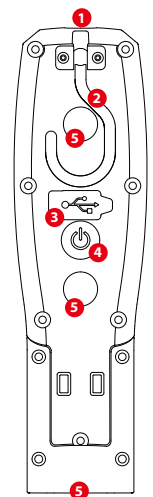

- 1** Top Light
- 2** Rigid plastic hook
- 3** USB-C Socket
- 4** On - Off switch
- 5** Magnet

Leak Detection UV Lights



LMF003-002

Folding Rechargeable SLIM UV Detection Light - Mini

395
Nanometer
COB LED



For detection of leakages in cooling systems,
used with UV detection liquid
Durable plastic housing, aluminum LED frame
Strong magnet on the bottom and back
180 degree rotating head in vertical position
During charging, the red led flashes, green led
indicates fully charged.

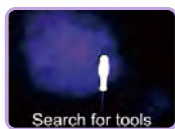
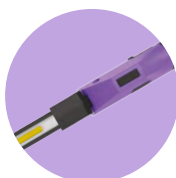

Flood light: Super Bright COB LED, 6500K, 80+CRI
Spot light: Super Bright LED, 6500K, 80+CRI
UV light: UV LED, 395 nm



Flood light: 300 lumens
Spot light: 80 lumens
Back light: 395 nm



Battery:
3.7 V 800 mAh Li-ion



Charging time:
3.5 h



Flood light: 1.5h
Spot light: 3 h
UV light: 3 h



1m Type C USB
5V-1A



IP54



IK07



80 g



Fold: 158x20x32 mm
Extend: 301x20x25 mm

- 1 Top Light
- 2 Main light
- 3 Magnet
- 4 Battery Indicator
- 5 On - Off switch
- 6 USB-C socket
- 7 Magnet
- 8 Magnet

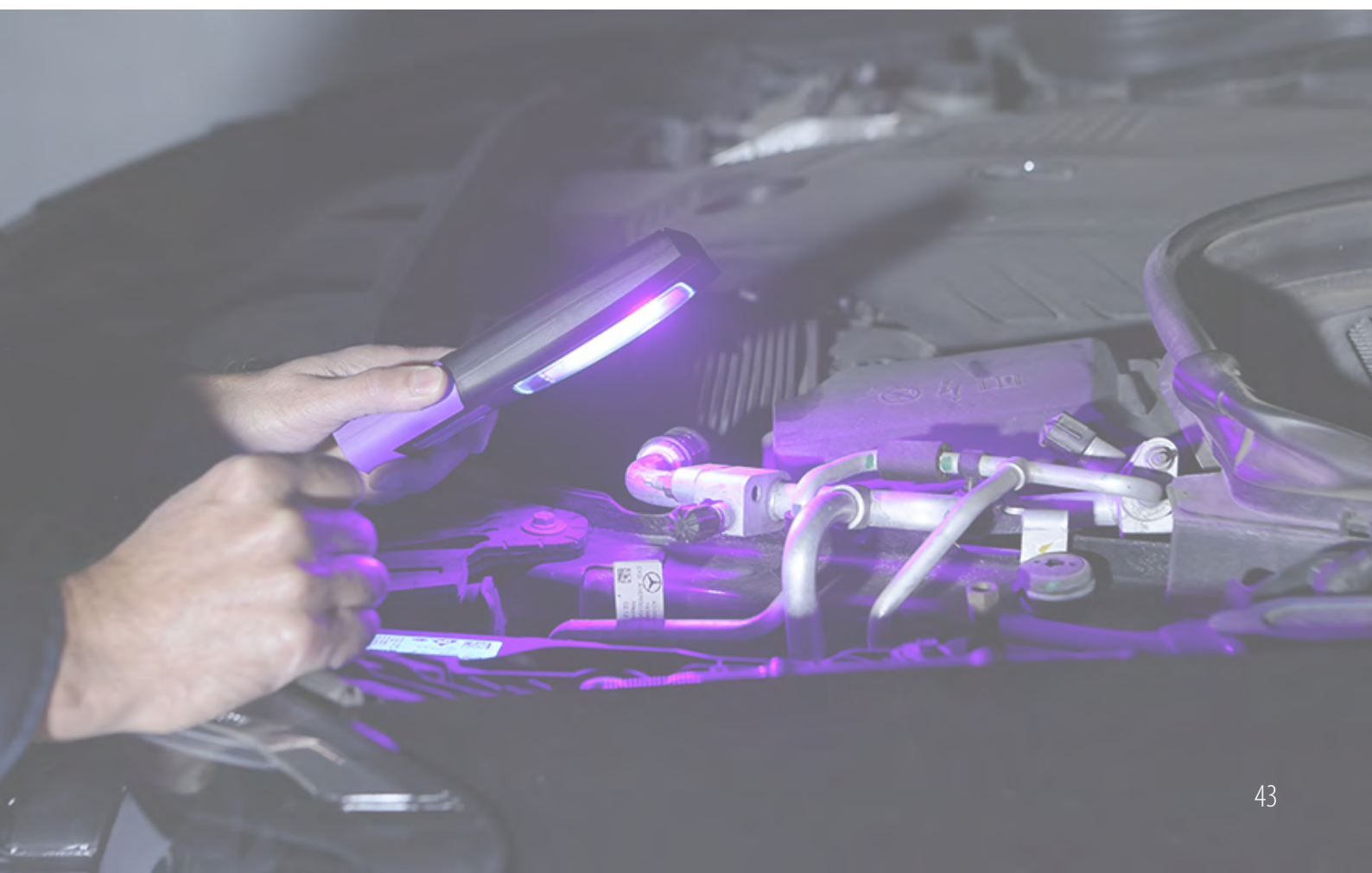
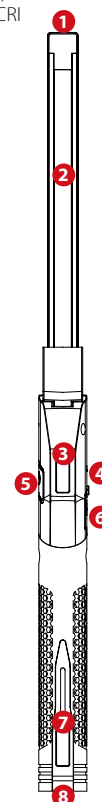

Underhood worklight



Underhood worklight



LMU001-001

Underhood worklight

2000
lumens
COB LED



Each lights has its own handy hanging hooks.
Both lights detach for convenient hand-held use.
This underhood can expanded from 1250mm to 2000mm.



- Flood light: 2x10W COB LED, 6500K, 80+CRI
- Flood light: 2x250 /2x500 /2x1000 lumens
- Battery: 2x 3.7V 4400mAh Li-ion or 2x 3.7V 2600mAh Li-ion
- Charging time: 4 h
- Flood light: 12 h /6 h /3 h
- 1m Type C USB 5V-2A
- IPX3
- IK07
- 1900 g
- 1260x65x140 mm

LMU002-001

Underhood worklight

2000
lumens
COB LED



Durable housing and lens.
180 degree flexible handle.
Super strong magnet on the handle.
4 LED battery level indicators during charging and discharging.







- Flood light: 2x10W COB LED, 5500-6500K
Spot light: Super Bright LED, 5500-6500K, 70+CRI
- Flood light: 2x250 / 2x500 / 2x1000 lumens
Spot light: 2x250 lumens
- Battery: 2x3.7 V 2600 mAh Li-ion
- Charging time: 3.5 h
- Flood light: 10 / 5 / 2 h
Spot light: 6 h
- 1m Type C USB 5V-1A
- IP65
- IK07
- 1764 g
- 1260x65x140 mm

LMX001-001

WORK LIGHT TRIPOD WITH
CARBON FIBER MATERIAL



-  Folded: 620mm
-  Extended: 1600mm
-  Section: 3
-  Max.Load: 1900g

Work Light Tripod



A partnership with Ceta Form Hand Tools, Türkiye

Factory:

WhatsApp: +86 18 9063 18277
WeChat: 1386 312 4456
ben.yu@sd-lumax.com PC: 264400
No.27-8, Sichan Road, Wendeng
Economic Development Zone, Weihai,
Shandong, China
www.sd-lumax.com

UK Sales Office:

Phone: +44 845 308 1440
Email: sales@cetaform.co.uk
Website: www.lumaxlighting.co.uk
Address: Windsor House, Cornwall
Road, Harrogate, HG1 2PW, UK